

Septic System Enhancement

Conventional septic systems utilize a septic tank to hold non-soluble materials and a soil absorption component (leach fields, for example) to provide the majority of treatment and disperse the wastewater. Over time, the soil absorption component can build up a clogging layer which can eventually prevent the wastewater from moving away from the system and through the soil. Sluggish flushing, soggy lawns, plumbing system backups or even surfacing wastewater can result. These unpleasant symptoms may force property owners to completely replace their soil absorption system. This drastic form of repair can be very costly and damaging to the existing property. There simply hasn't been much choice...until now.

Dependable, Affordable FAST

RetroFAST® wastewater treatment systems are used as an enhancement for conventional septic systems and provide a simple upgrade to renovate biologically failed septic systems. RetroFAST also reduces the concentration of high strength waste, making it a good fit for many troubled systems. When used with new home construction, the RetroFAST delivers high levels of treatment to help assure the clogging layer never forms in the first place.

Minimal Site Disruption

RetroFAST is designed to be adapted and inserted into an existing tank resulting in minimal site disruption. Minor modification to the existing soil absorption system may be advisable.

Low Cost, Long Lasting Solution

Modernizing the wastewater treatment system with RetroFAST increases value and usefulness of the property.

Simple, Dependable Retrofit

Small communities now have a practical, proven alternative to cost prohibitive centralized sewer systems. Septic systems can receive significant upgrades in their performance (including Nitrogen reduction) with the appropriate use of RetroFAST.



RetroFAST[®] wastewater treatment systems

How Does It Work?

When highly treated wastewater with dissolved oxygen is applied to a biologically failing soil absorption system, the clogging layer can actually repair itself. This occurs because RetroFAST[®] removes the type of pollutants that originally formed the clogging layer, and RetroFAST's oxygenated effluent fosters the development of aerobic bacteria in the soil that will naturally digest the existing clog.

Will it Work At My Site?

Most new conventional systems or biologically failed systems are good candidates for enhancement with RetroFAST, but every situation is unique. Please consult Bio-Microbics or the dealer nearest you for more information to determine if RetroFAST is right for your application.

Proven, Safe, Reliable.

The advanced technology behind FAST[®] was originally developed by Smith & Loveless, Inc., a worldwide leader in the design and manufacture of wastewater treatment equipment since 1946. FAST has been used successfully for over 30 years in municipal, industrial, marine, commercial and residential applications.

Each RetroFAST unit comes equipped with the RetroFAST insert, insert lid, a blower assembly, blower housing and other needed hardware. The regenerative-type blower shall be mounted remote from the RetroFAST unit up to 100 feet (30.5 m) maximum. A two-piece, insulated housing is provided with tamper-proof screws. Power required: Normal household current (120v, 60Hz). Other options (220v and international requirements) are available. Made with 100% corrosion-resistant material. FAST systems can be housed in concrete, fiberglass, steel or plastic tanks. Always check local regulations before installing or altering a wastewater system. Contact a dealer near you for more information.

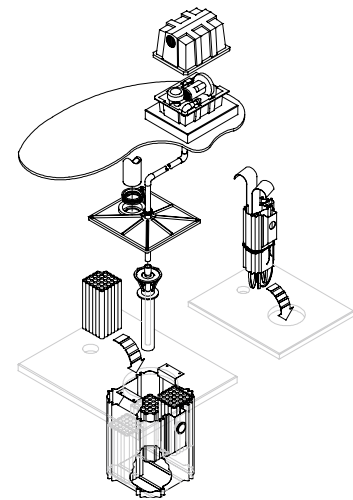

In the Interest of technological progress, RetroFAST Water Treatment Systems are subject to design and/or material changes without notice.

RetroFAST[®] wastewater treatment systems Specifications

Retrofit Applications	Maximum Treatment Capacity*		Blower Capacity	Minimum Tank Dimensions*** [-18" (45.7cm) diameter opening required]	Weight*** [Metric]
	Volume/Module**	Persons /Module**			
RetroFAST 0.25	250 GPD (947 LPD)	1 to 4 persons	1/8 HP 6-17 cfm	28" L (71.1 cm) x 24" W (61 cm) x 33.5" H (85.1 cm)	56.7 kg
RetroFAST 0.375	375 GPD (1420 LPD)	1 to 5 persons	1/4 HP 9-24 cfm	41" L (104.1 cm) x 24" W (61 cm) x 33.5" H (85.1 cm)	70.8 kg

***Treatment capacity:** Individual FAST module capacities are rated based on biological (BOD), hydraulic and other project-specific considerations. All rated capacities are given as guidelines for suggested use. Actual capacity may vary with local conditions and performance goals.

****Volume/Persons per module:** Please note that only residential applications or those applications requiring treatment for only sanitary wastewater, may be designed from the volume and number of persons per module. Actual capacity may vary with local conditions and performance goals.

*****Module dimensions/weight** provided only for shipping specifications. Please see design specifications for recommended exterior tankage sizing. Treatment modules shall be installed inside tanks that are locally approved and manufactured using watertight materials.

Electrical Options: Electrical components are available to meet all worldwide electrical specifications (volt/phase/frequency).



FAST Certifications Include:

U.S. Coast Guard • Canadian Great Lakes • UK Department of Trade • NSF Standard 40, Class I • International Maritime Organization (IMO) • Royal Australian Navy SASSO-Saudi Arabian Standards Organization • USEPA-Environmental Technology Verification (ETV) • C.S.A.-Canadian Standards Association • Underwriters Laboratories (UL) C.E.-European Electrical Systems



Better Water. Better World.

8450 Cole Parkway, Shawnee, KS 66227 • 1.800.753.FAST (3278) • Ph: 913.422.0707 • Fax: 913.422.0808 • Email: sales@biomicrobics.com • URL: www.biomicrobics.com